

Schematic Diagrams

INTRODUCTION

THIS CHAPTER contains the schematic diagrams for your Knuckle Bash™ game PCB and JAMMA filter PCB. The game PCB and JAMMA filter PCB *assembly drawings* are illustrated in Chapter 3, Parts Illustrations.

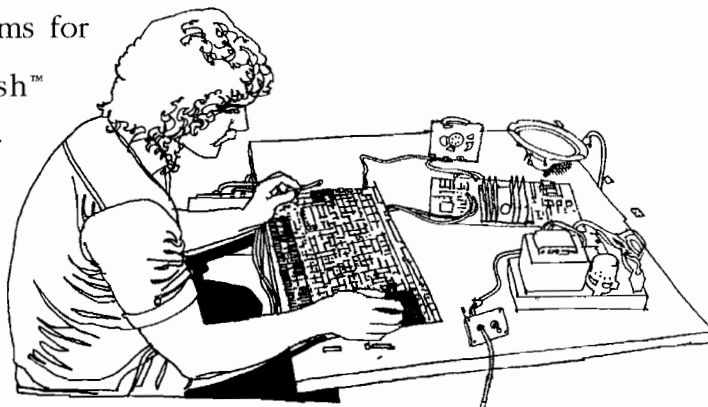

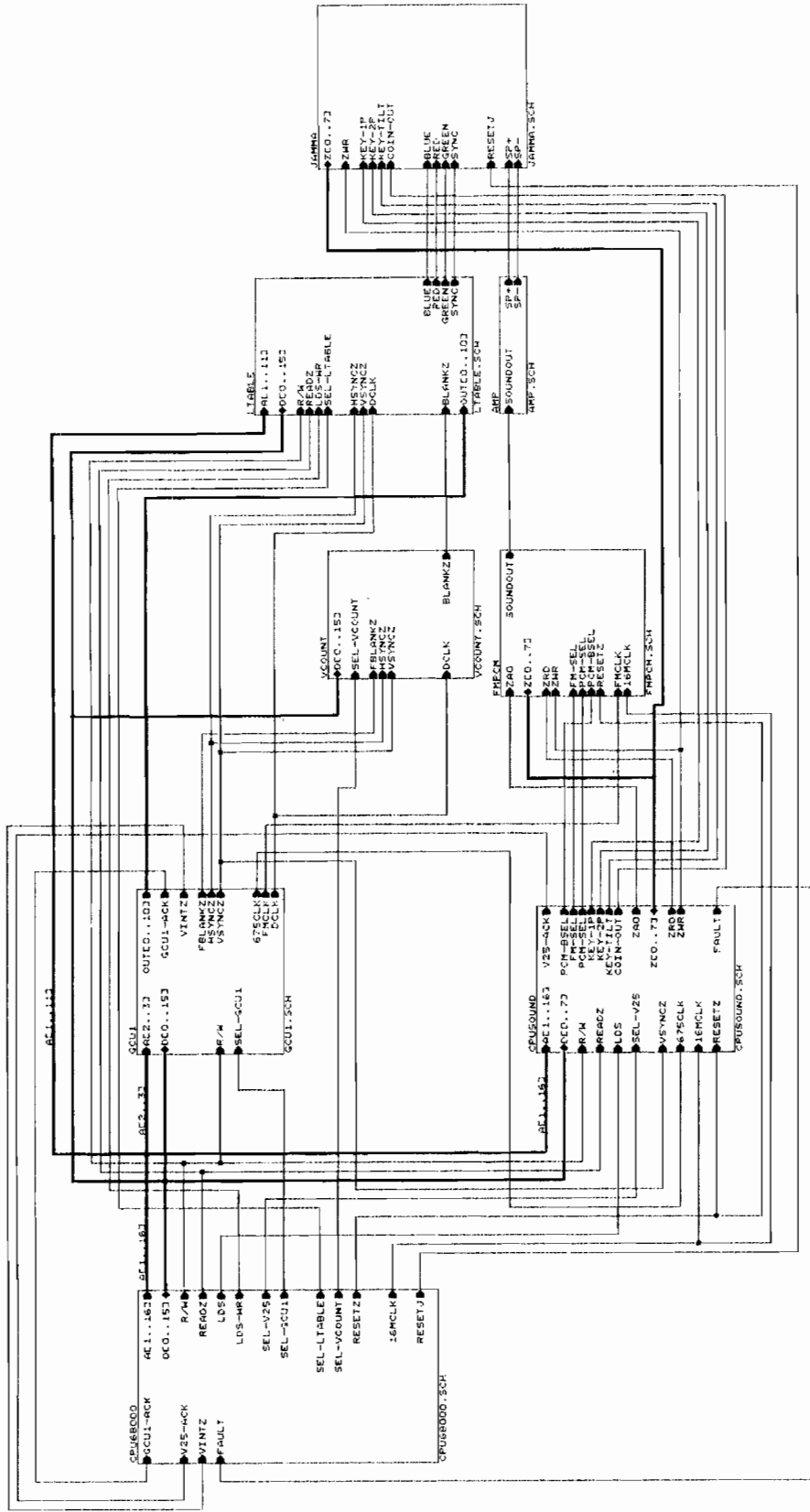

Figure 4-1 Knuckle Bash Game PCB Schematic Diagram
Circuit Overview Diagram

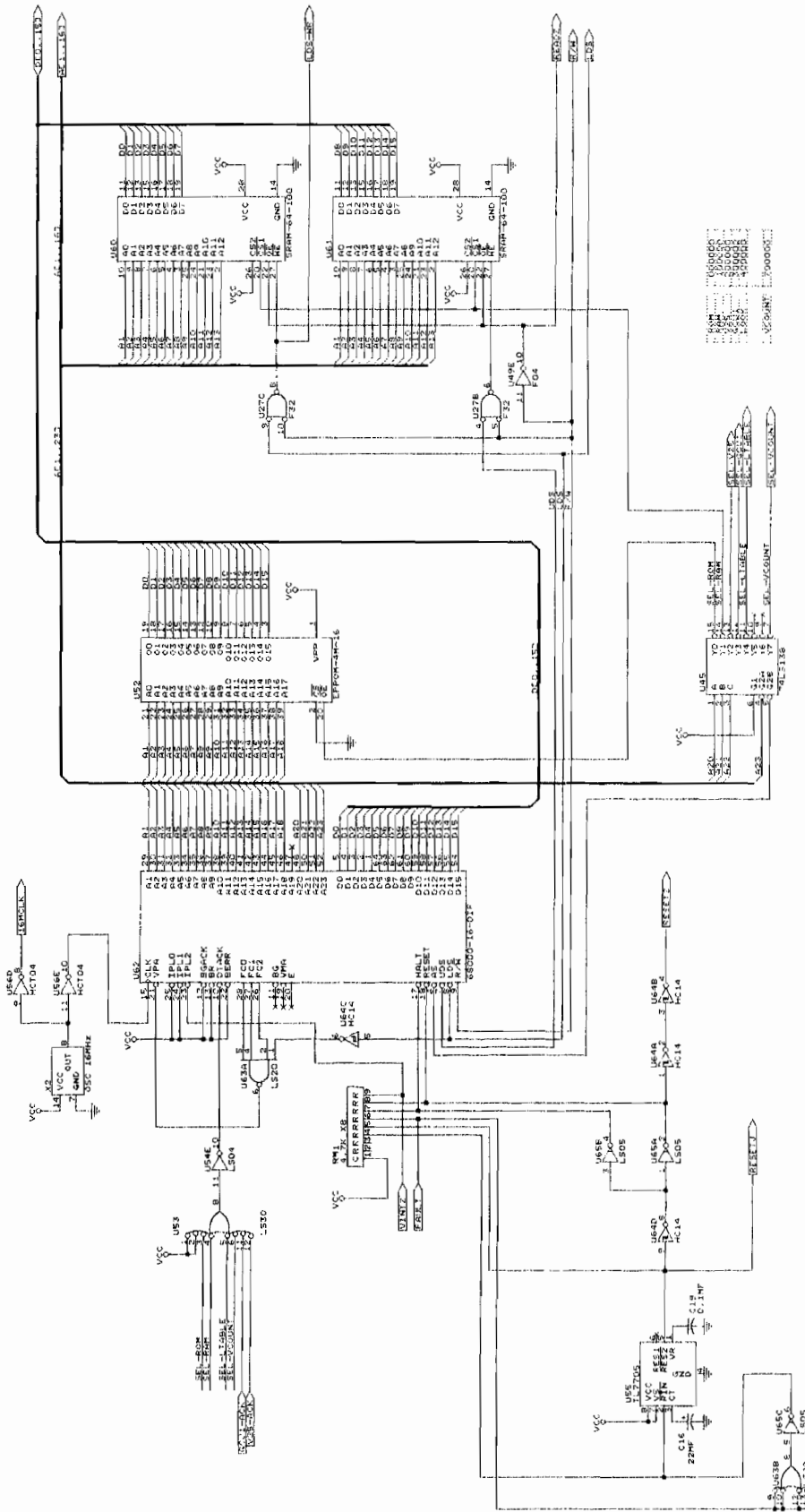

Figure 4-2 Knuckle Bash Game PCB Schematic Diagram

Graphics CPU

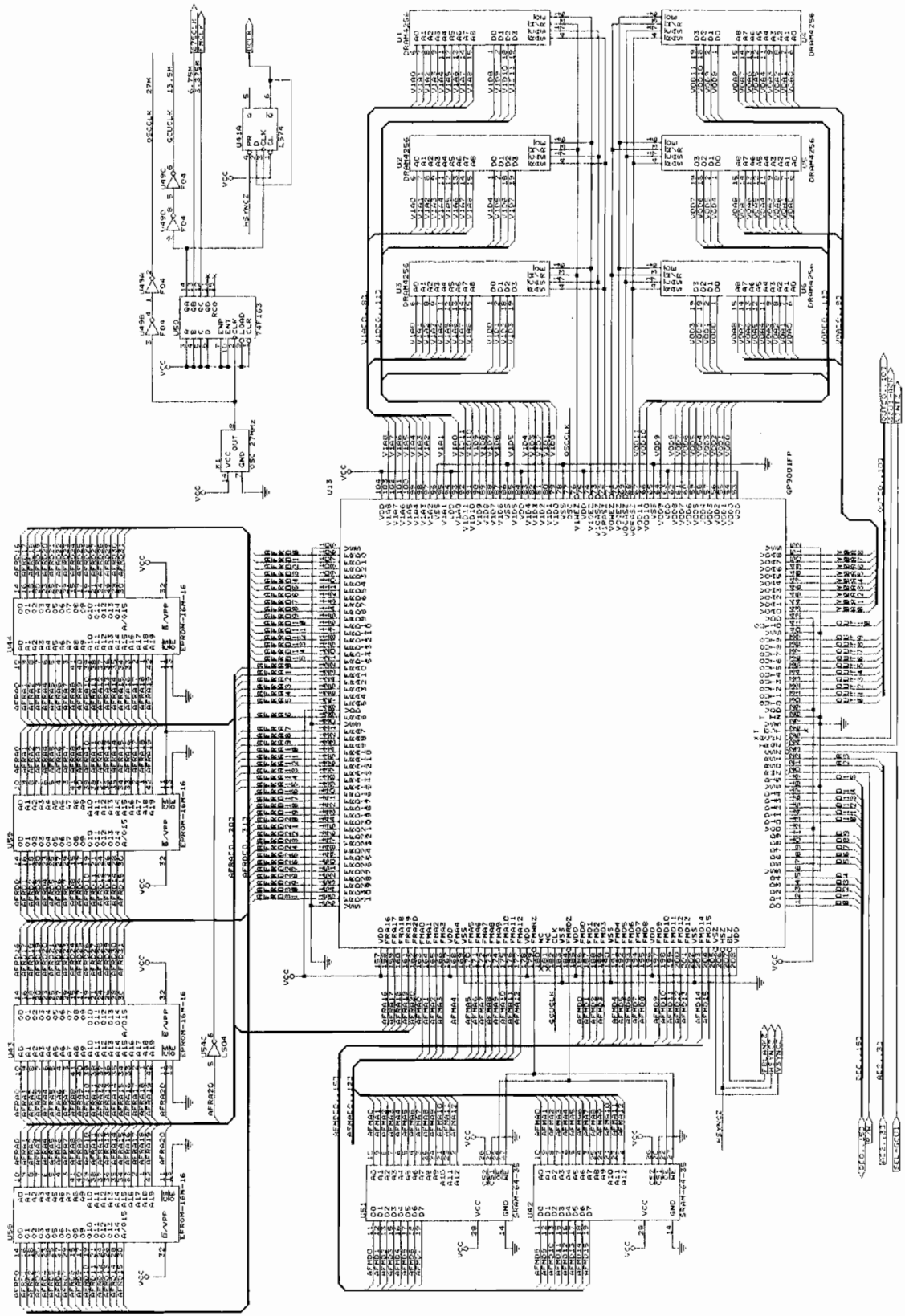

Figure 4-3 Knuckle Bash Game PCB Schematic Diagram
Graphics Control Unit

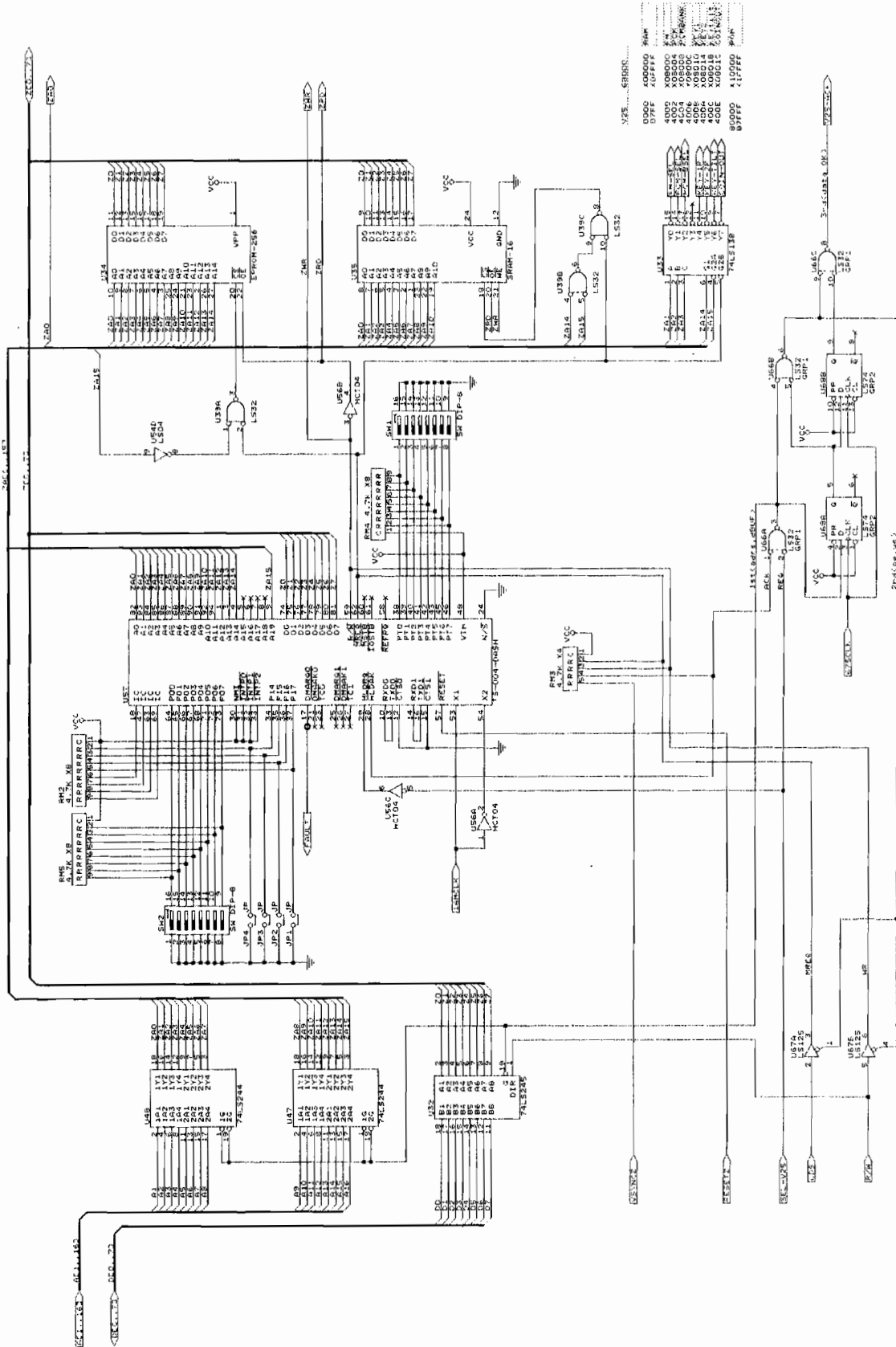

Figure 4-4 Knuckle Bash Game PCB Schematic Diagram
Sound and I/O Processor

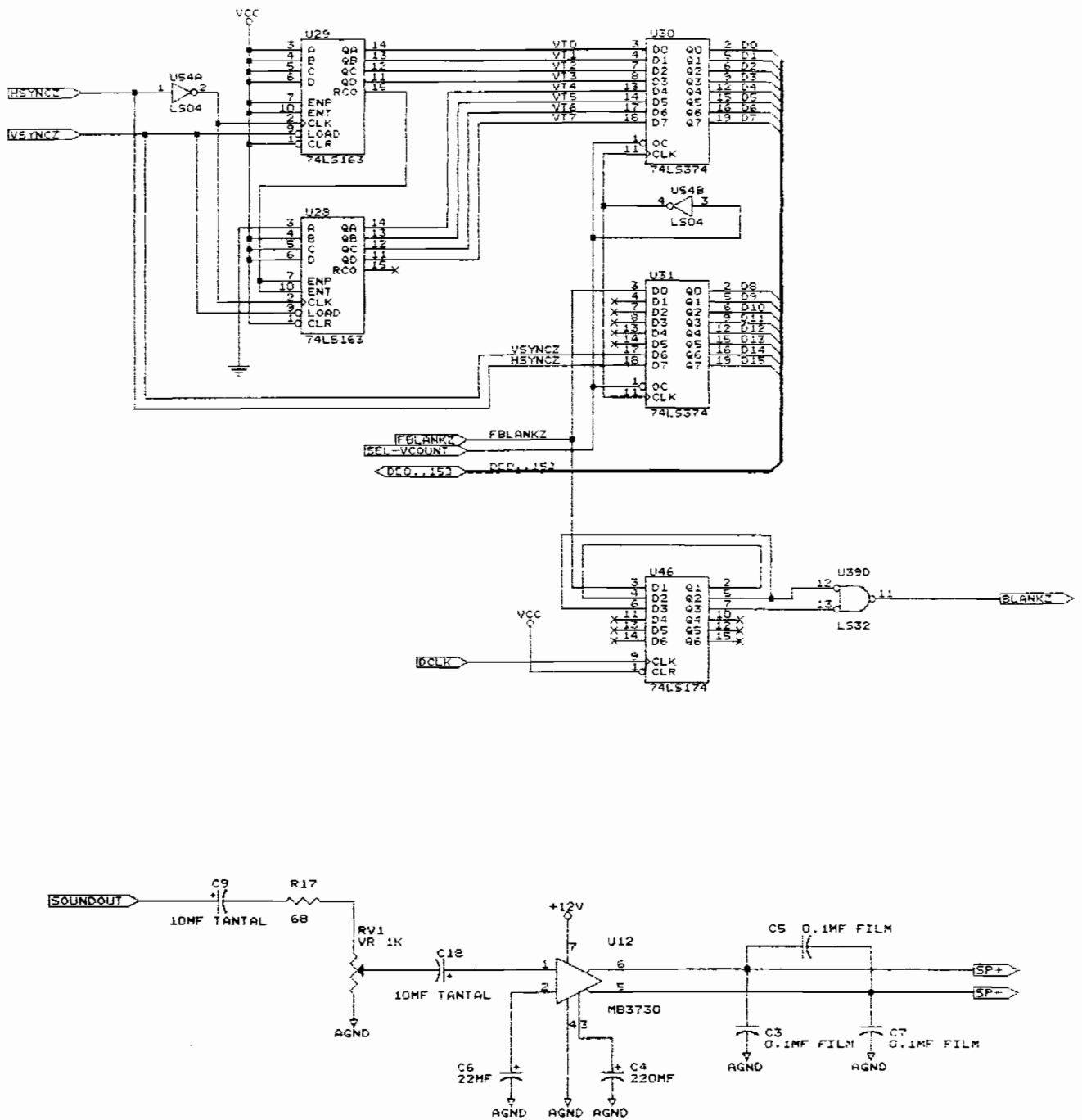

Figure 4-5 Knuckle Bash Game PCB Schematic Diagram

Vertical Line-Counter (top) and Audio Amplifier (bottom)

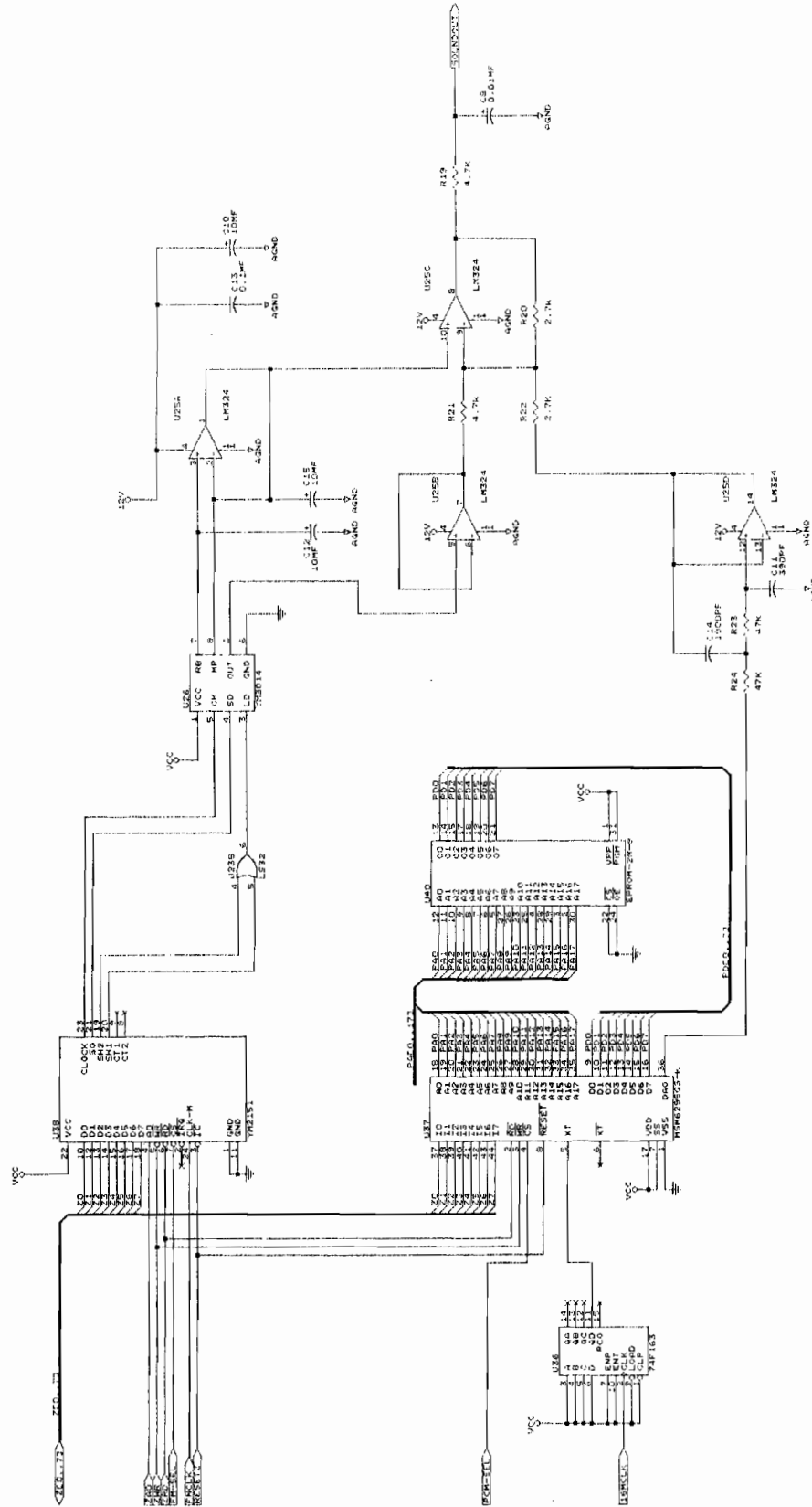

Figure 4-6 Knuckle Bash Game PCB Schematic Diagram
FM and ADPCM Sound Generation

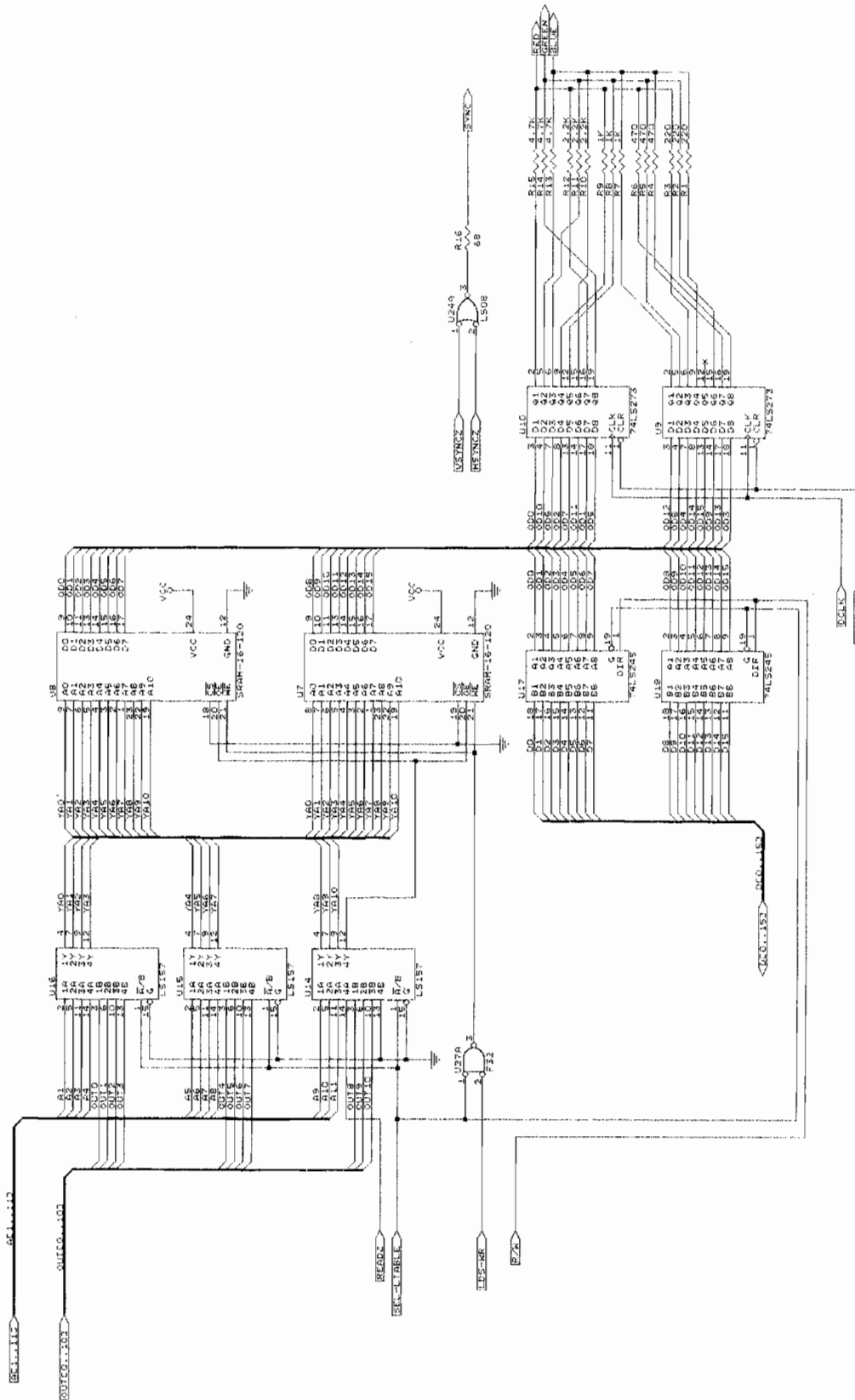

Figure 4-7 Knuckle Bash Game PCB Schematic Diagram
Color Palette Look-up and Video Out

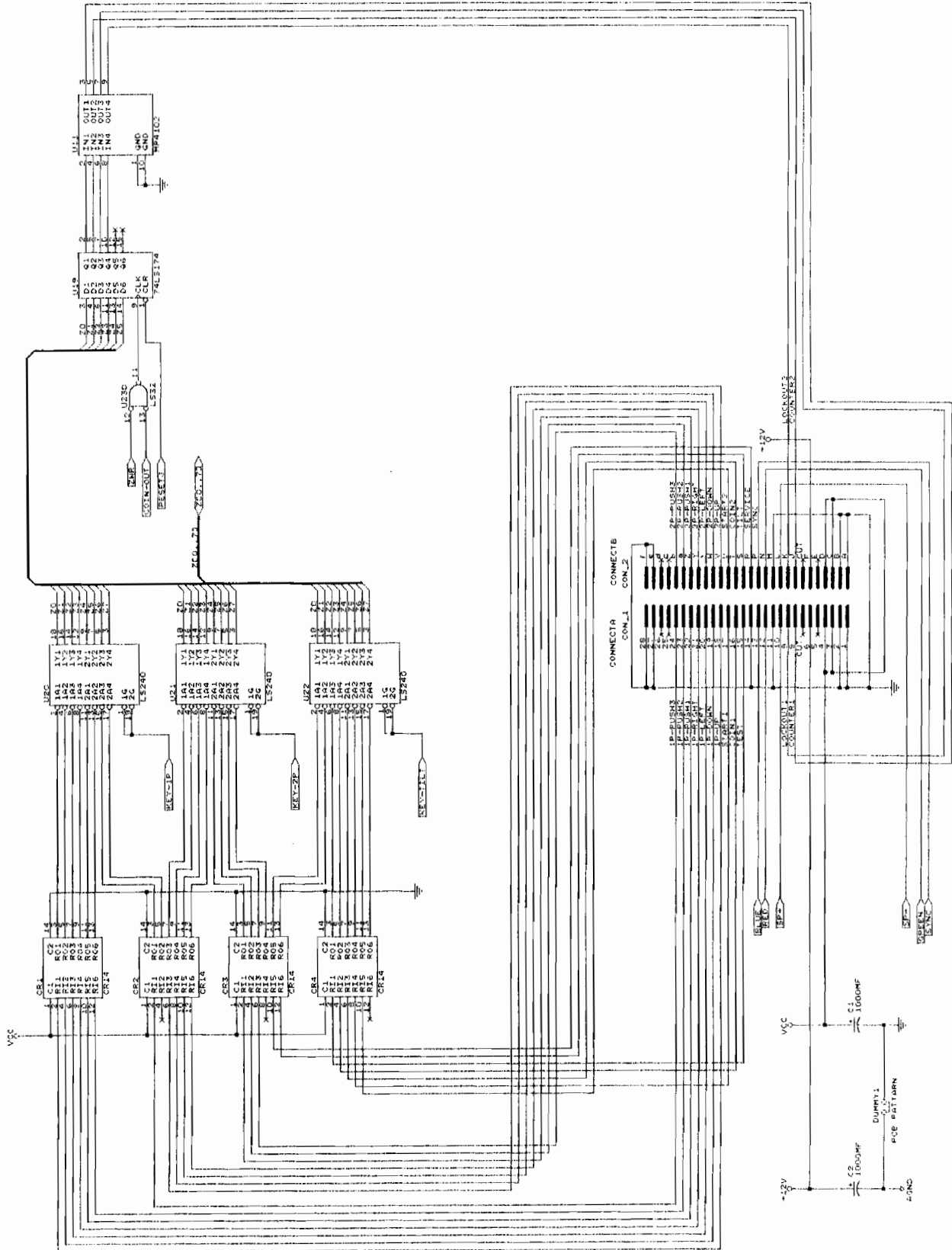

Figure 4-8 Knuckle Bash Game PCB Schematic Diagram
JAMMA and I/O Interface

FROM GAME BOARD

- 1 O → GND
- 2 O → GND
- 3 O → J1+5V
- 4 O → J1+5V
- 5 O → J1-5V
- 6 O → J1+12V
- 7 O → KEY
- 8 O → J1CNTR2
- 9 O → J1LOCK2
- 10 O → J1SPKR1-
- 11 O → J1AUDGND
- 12 O → J1GREEN
- 13 O → J1SYNC
- 14 O → J1SERV
- 15 O → J1TILT
- 16 O → J1RCOIN
- 17 O → J1START2
- 18 O → J1UP2A
- 19 O → J1DOWN2A
- 20 O → J1LEFT2A
- 21 O → J1RT2A
- 22 O → J1FTR2
- 23 O → J1UP2B
- 24 O → J1DOWN2B
- 25 O → J1LEFT2B
- 26 O → J1RT2B
- 27 O → GND
- 28 O → GND
- A O → GND
- B O → GND
- C O → J1+5V
- D O → J1+5V
- E O → J1-5V
- F O → J1+12V
- H O → KEY
- J O → J1CNTR1
- K O → J1LOCK1
- L O → J1SPKR1+
- M O → J1AUD+
- N O → J1RCO
- P O → J1BLUE
- R O → J1VIDGND
- S O → J1SLFTST
- T O → J1LCOIN
- U O → J1START1
- V O → J1UP1A
- W O → J1DOWN1A
- X O → J1LEFT1A
- Y O → J1RT1A
- Z O → J1FTR1
- AA O → J1UP1B
- BB O → J1DOWN1B
- CC O → J1LEFT1B
- DD O → J1RT1B
- EE O → GND
- FF O → GND

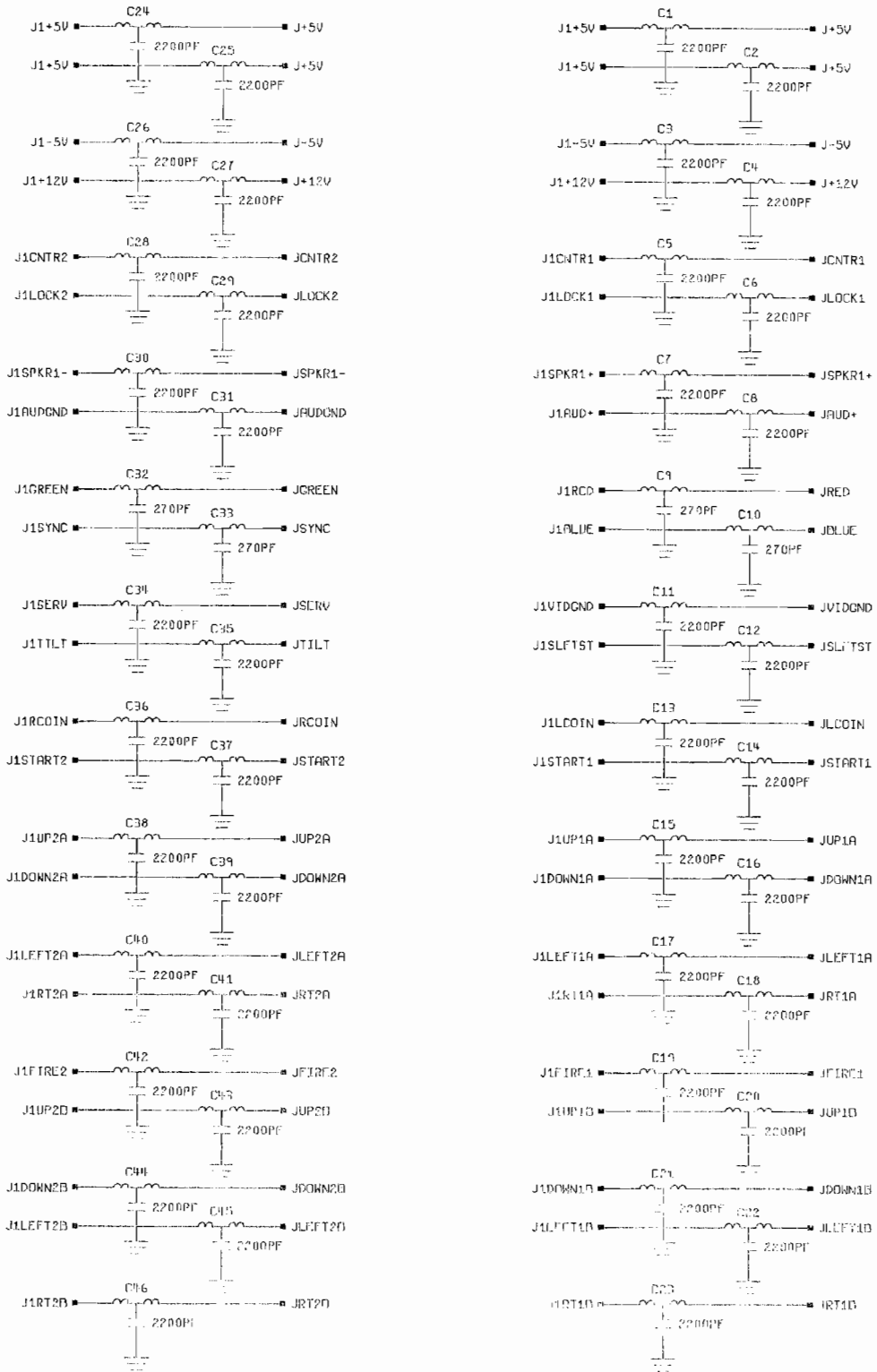

Figure 4-9 JAMMA Filter PCB Schematic Diagram

A047292-02 A

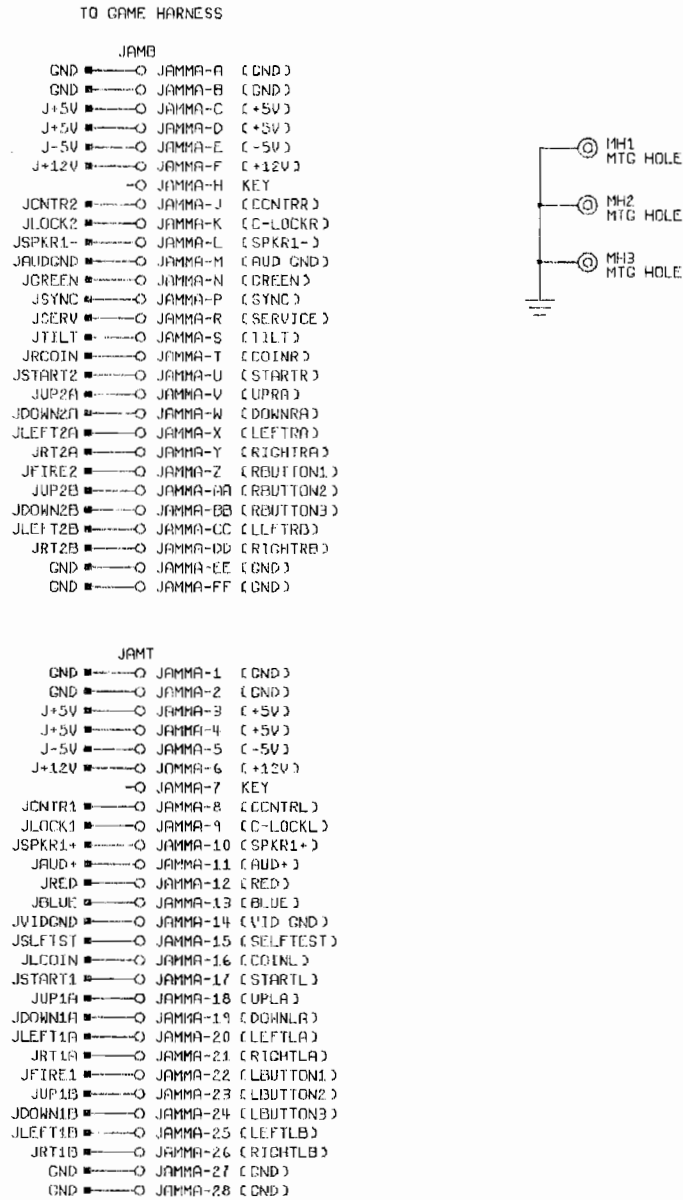

Figure 4-9 JAMMA Filter PCB Schematic Diagram, Continued

A047292-02 A

N O T E S

Warranty

Seller warrants that its printed-circuit boards and parts thereon are free from defects in material and workmanship under normal use and service for a period of ninety (90) days from date of shipment. Seller warrants that its video displays and laser-video disc players (in games supplied with displays and video-disc players) are free from defects in material and workmanship under normal use and service for a period of thirty (30) days from date of shipment. None of the Seller's other products or parts thereof are warranted.

If the products described in this manual fail to conform to this warranty, Seller's sole liability shall be, at its option, to repair, replace, or credit Buyer's account for such products which are returned to Seller during said warranty period, provided:

- (a) Seller is promptly notified in writing upon discovery by Buyer that said products are defective;
- (b) Such products are returned prepaid to Seller's plant; and
- (c) Seller's examination of said products discloses to Seller's satisfaction that such alleged defects existed and were not caused by accident, misuse, neglect, alteration, improper repair, installation, or improper testing.

In no event shall Seller be liable for loss of profits, loss of use, incidental or consequential damages.

Except for any express warranty set forth in a written contract between Seller and Buyer which contract supersedes the terms herein, this warranty is expressed in lieu of all other warranties expressed or implied, including the implied warranties of merchantability and fitness for a particular purpose, and of all other obligations or liabilities on the Seller's part, and it neither assumes nor authorizes any other person to assume for the Seller any other liabilities in connection with the sale of products by Seller.

The use of any non-Atari parts may void your warranty, according to the terms of the warranty. The use of any non-Atari parts may also adversely affect the safety of your game and cause injury to you and others. Be very cautious in using non-Atari-supplied components with our games, in order to ensure your safety.

Atari distributors are independent, being privately owned and operated. In their judgment they may sell parts or accessories other than Atari parts or accessories. Atari Games Corporation cannot be responsible for the quality, suitability or safety of any non-Atari part or any modification including labor which is performed by such distributor.



Atari Games Corporation

675 Sycamore Drive

Milpitas, CA 95035

U.S.A.